

CMAXXX

DUST & FUME COLLECTION SYSTEM





OUR MISSION

**“TO IMPROVE THE HEALTH, SAFETY,
AND QUALITY OF PEOPLE’S LIVES
BY BUILDING THE BEST DUST AND
FUME COLLECTORS ON EARTH”**

IMPERIAL SYSTEMS, INC.

B R E A T H E B E T T E R , W O R K S A F E R

THE MOST ADVANCED

& SAFEST DUST

COLLECTOR

ON EARTH



CMAXX IDA TESTING

The CMAXX, along with the proprietary IDA DeltaMAXX filters, has been PROVEN to isolate a deflagration and stop a flame front. Third party testing of the CMAXX shows explosive flame front being forced through the vent. With the explosion vent covered, 100% of the flame front was forced through the IDA DeltaMAXX filters and NO spark or flame was present.

Using a CMAXX without explosion venting, the unit's body was also tested to withstand a deflagration of corn starch at 185 KST with pressures exceeding 4 PSI. The entire explosion diverted through the IDA DeltaMAXX filters, which showed no sign of deformation. The internal cages of the filters remained in perfect shape and the seals were not deformed or melted whatsoever. All testing, proving that the CMAXX can be used as a flame front deflagration arrestor/arrester when used in conjunction with IDA DeltaMAXX filters, is backed by third party testing. Reports and test results can be provided upon request.

In addition, the IDA DeltaMAXX filters work off of the same primary cleaning system that the CMAXX uses, ensuring that the filters are consistently cleaned during operation. Similar systems that use after filters do not have any means for online cleaning.

The results conform to NFPA 69 12.2.5.2 Static Dry Flame Arrester Designs and Chapter 5 under performance based option, both NFPA 654 to prevent the "extension of the flame front outside the compartment or equipment of origin except where intentionally vented to a safe location" 5.2.5 (2) and NFPA 69 "to limit and risk of flame spread from vessel to vessel via interconnecting ducts" 5.2.4 (3), 5.2.5 (2).

This CMAXX Dust Collector is IDA (In-Line Deflagration Arrester) certified and rated up to 180 KST and 4 psi maximum dust explosion pressure. Use only IDA DeltaMAXX™ filters to keep this certification and the 15 year warranty legally valid.

To replace the IDA filters call:
800-918-3013

IDA CERTIFIED



**INDUSTRY
LEADING**

Lifetime
WARRANTY

Imperial Systems, Inc. warrants to the original purchaser that the major structural components of the CMAXX™ dust collector will be free from defects in materials and workmanship for the lifetime of the equipment, if properly installed, maintained and operated under normal conditions. Imperial Systems, Inc. warrants filter cartridges to be free from defects in materials and workmanship for twelve (12) months from date of shipment. Imperial Systems, Inc. does not warrant damages which are due to corrosion, abrasion, normal wear and tear, product modification or product misapplication. Imperial Systems, Inc. also makes no warranty whatsoever as to any goods manufactured or supplied by others, including, but not limited to, electric motors and control components. After Imperial Systems, Inc. has been given adequate opportunity to remedy any defects in material or workmanship, Imperial Systems, Inc. retains the sole option to accept return of the goods, with freight paid by the purchaser, and to refund the purchase price for the goods on a prorated

basis after confirming the goods are returned undamaged and in usable condition. Such a refund will be the full extent of Imperial Systems, Inc. liability. Imperial Systems, Inc. shall not be liable for any other costs, expenses or damages, whether direct, indirect, special, incidental, consequential or otherwise. The terms of this warranty may be modified only by a special warranty document signed by the President of Imperial Systems, Inc. There exist no other representations, warranties or guarantees except as stated in this paragraph. All other warranties, including merchant-ability and fitness for a particular purpose, whether express or implied, are hereby expressly excluded and disclaimed.

BREATHE BETTER, WORK SAFER

F O R L I F E

**FAILURE TO USE GENUINE IMPERIAL
SYSTEMS, INC. REPLACEMENT PARTS
& FILTERS WILL VOID THIS WARRANTY.**



COMPARISON CHECKLIST



Leading Vertical Filter Cartridge
Dust Collector

Leading Horizontal Filter Cartridge
Dust Collector

Arched Roof	●		
Vertical Cartridge Filters	●	●	
No External Bolt Holes	●		
Modular Design	●	●	●
Heavy Duty Doors	●		
7 & 10 Gauge Construction	●	●	
Various Filter Medias	●	●	●
Variety of Applications	●	●	●
Easy Filter Access	●	●	
Custom Powder Coat	●	●	
Even Lock Technology Lift Rails	●		
Anti-Ramp Filter Rail	●		
Lifetime Warranty	●		
In-line Pulse Valves	●		
Custom Design	●		

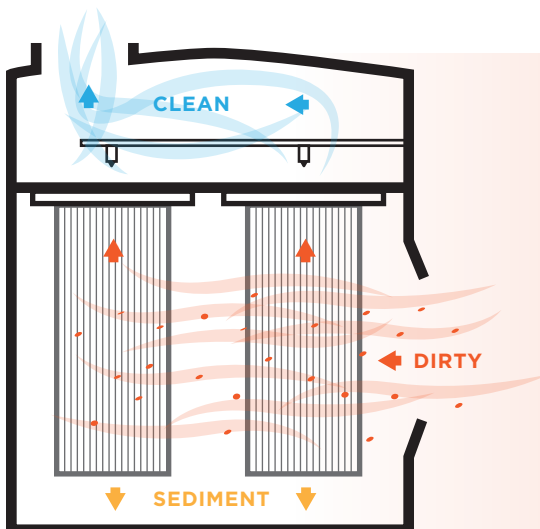

HOW IT WORKS

Dirty air is pulled in from duct work and particulates are captured by the DeltaMAXX™ filters. The clean air is pulled through the filter media and up into the clean air plenum. The air then exits the collector and goes to the return air duct. Compressed air pulses down into the filter cleaning it from the inside out. The dust cake built on the filter is then knocked down into the grating below or into a hopper.

CMAXX APPLICATIONS

Imperial Systems has a long line of successful grain dust collection systems installations. Our CMAXX dust collection systems span from small processing mills to some of the country's largest grain export terminals.

GRAIN INDUSTRY



PLASMA CUTTING

Imperial Systems' CMAXX is the perfect modular collector for plasma cutting dust collection. The CMAXX comes in many different variations and is modular in design so making a standard model custom is an easy task.



The CMAXX Dust Collector is the perfect solution for welding shops and schools. From Source Capture to Ambient Systems, the CMAXX easily handles any of your welding fume extraction needs and more.

WELDING FUMES



SILICA DUST

The CMAXX Silica Dust Filtration System can be customized to fit your dust collection needs. The CMAXX dust collector with DELTAMAXX Cartridge Filters will make most any Silica Dust application process an easy task. We work with many customers that need custom solutions.



Imperial Systems has a long line of successful dust collection installations in fiberglass. With our turn key capabilities and extensive background in fiberglass dust collection we are truly one of the country's biggest names in the fiberglass industry.

FIBERGLASS DUST



SHOT BLASTING

Blasting is a very diverse market and includes a large variety of different medias from sand to plastic. The CMAXX Dust Collector System has specially designed features that are suitable for all blasting applications.

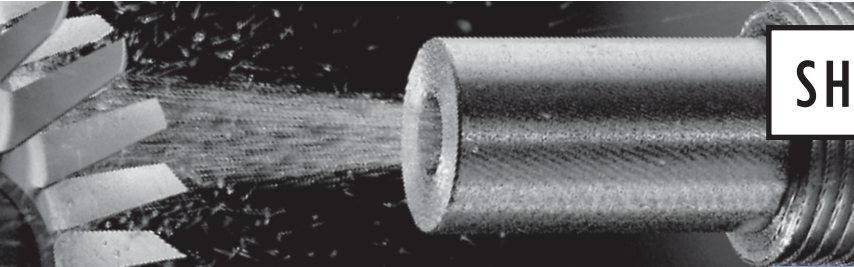

Imperial Systems has a long line of successful woodworking dust collection system installations in the industry. Our woodworking dust collection systems span from small cabinet shops to some of the largest names in flooring.

WOODWORKING



COMBUSTIBLE DUST & FIRE ACCESSORIES

1

SPARK TRAP

Extinguishes sparks and burning embers.
Reduces the risk of fires and explosions.
Heavy duty construction.
No moving parts and No maintenance.
Can be installed vertically or horizontally.

2

EXPLOSION ISOLATION VALVE

The installation of an explosion isolation device on all suction side ducts that transport material with a Kst value above zero is an NFPA requirement. Installing a Explosion Isolation Valve will protect workers and facilities from the damaging effect of a baghouse or filter explosion.

3

FAST ACTING SLIDE GATE

Pneumatic Slide Gates are engineered to control air flow and conserve energy. These gates deliver a positive shut-off to service machinery or to divert air.
Remote operation, machine integrated.
Safety guards reduce the risk of injury.

4

SPARK DETECTION

Fire and explosion prevention.
Explosion and spark is registered to the millisecond.
Eliminates Ignition source.
Risk management of your production process.

5

FIKE FIRE SUPPRESSION

Fike fire protection systems are effective, easy to use, and safe for people, key assets, facilities and the environment. Whether your needs are industrial, commercial or special hazard applications.
Total flooding suppression agent.

6

FIRE TRACE

Passive, self-actuating fire suppression system.
Indirect and Direct release systems using polymer tubing.
Compatible with most fire suppression agents.
Suppresses fire at the source and in seconds.

7

SMOKE DETECTOR

It detects smoke and will automatically shut down the collector. It can also engage any action that can be directly wired to the smoke detector to further prevent a flame front or damage to the collector or facility.

8

CHEMICAL EXPLOSION ISOLATION

Rapid discharge of a chemical explosion suppressant to prevent the flame from continuing through to other areas of your system.
Inlet and outlet application.
Used when venting is not an option.
For applications up to 400 Kst

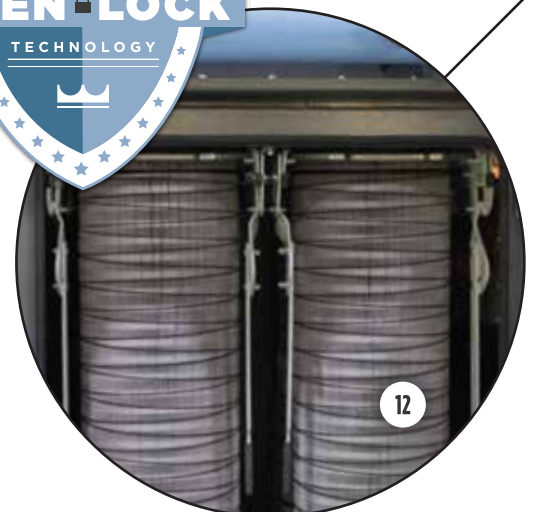
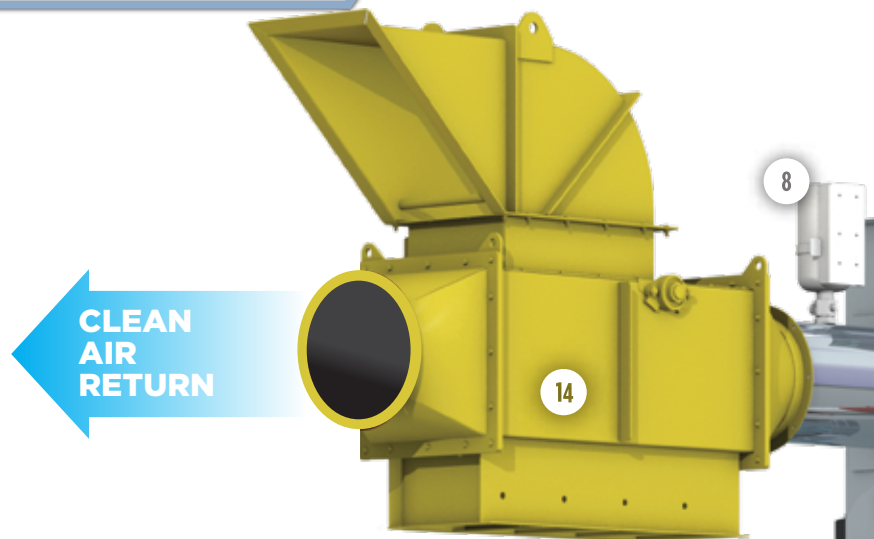

DELTA MAXX[™]
PRIME

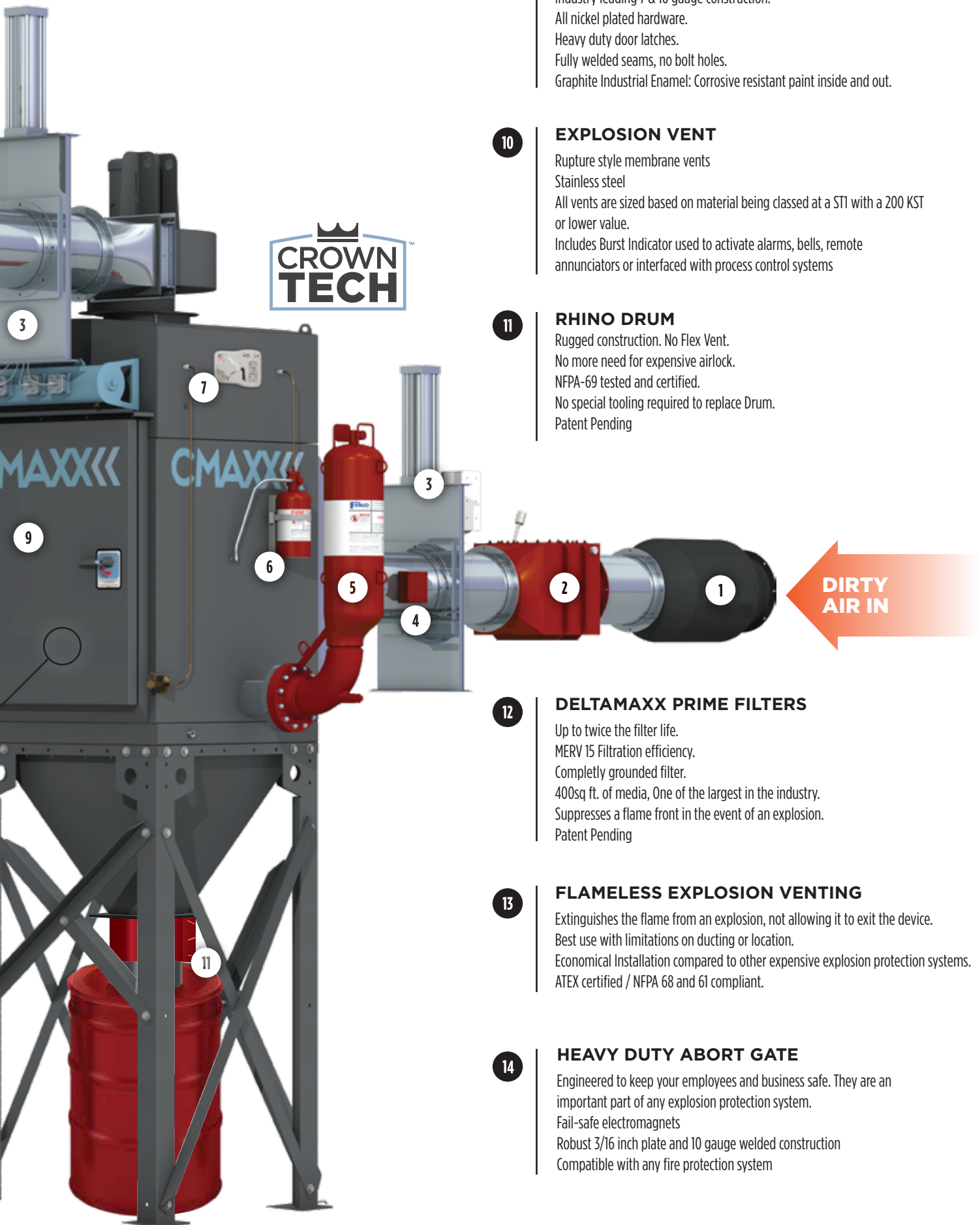

9

HEAVY DUTY CONSTRUCTION

Industry leading 7 & 10 gauge construction.
 All nickel plated hardware.
 Heavy duty door latches.
 Fully welded seams, no bolt holes.
 Graphite Industrial Enamel: Corrosive resistant paint inside and out.

10

EXPLOSION VENT

Rupture style membrane vents
 Stainless steel
 All vents are sized based on material being classed at a ST1 with a 200 KST or lower value.
 Includes Burst Indicator used to activate alarms, bells, remote annunciators or interfaced with process control systems

11

RHINO DRUM

Rugged construction. No Flex Vent.
 No more need for expensive airlock.
 NFPA-69 tested and certified.
 No special tooling required to replace Drum.
 Patent Pending

12

DELTAMAXX PRIME FILTERS

Up to twice the filter life.
 MERV 15 Filtration efficiency.
 Completely grounded filter.
 400sq. ft. of media, One of the largest in the industry.
 Suppresses a flame front in the event of an explosion.
 Patent Pending

13

FLAMELESS EXPLOSION VENTING

Extinguishes the flame from an explosion, not allowing it to exit the device.
 Best use with limitations on ducting or location.
 Economical Installation compared to other expensive explosion protection systems.
 ATEX certified / NFPA 68 and 61 compliant.

14

HEAVY DUTY ABORT GATE

Engineered to keep your employees and business safe. They are an important part of any explosion protection system.
 Fail-safe electromagnets
 Robust 3/16 inch plate and 10 gauge welded construction
 Compatible with any fire protection system

Explosion Isolation Valve (EIV)

Spark Trap

Abrasion Resistant Inlet or Space Saving Inlet

Standard Access Panel

Explosion Panel

Inlet Baffles



Drop Out Module

Standard Drum Kit

Pyramid Hopper

RHINO DRUM



EXPLOSION TESTED DRUM KIT
PATENT PENDING

- Explosion Tested to 7psi
- Meets Standards for NFPA 69/654
- Bonded to a Grounded Collector
- No Moving Parts
- No Flex Hose
- Tool Free

Eliminates need for Airlock - Half the Cost

No need for wiring/ maintenance/
motor/ starter/ wipers/ chains



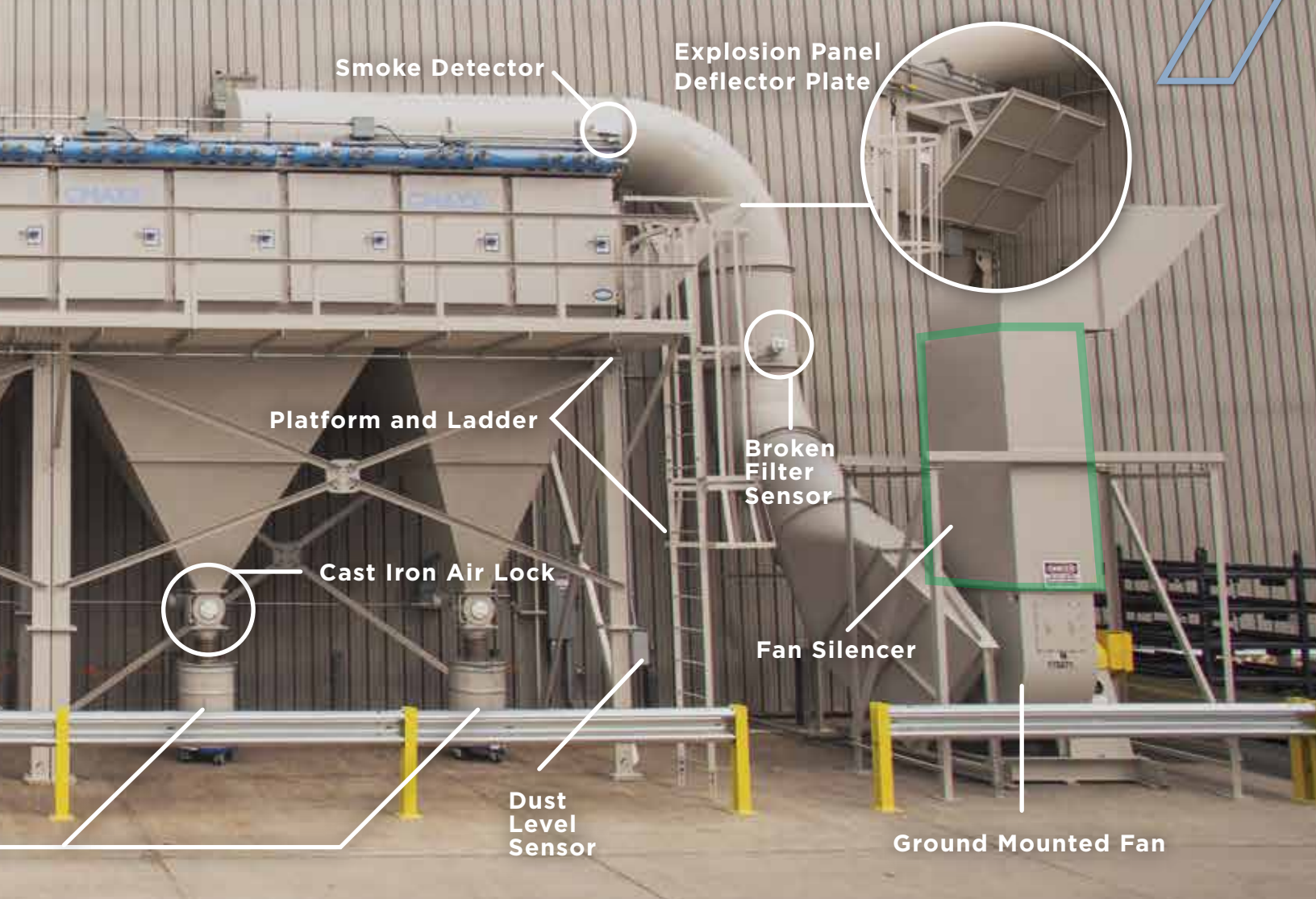

DUST LEVEL SENSOR

PATENT PENDING

- Easy install and setup
- Low voltage
- Ideal for hard to check containers
- Prevent container overflow
- Less need to open containers
- Eliminates risk of dust backing up
- Half the cost of competing sensors

The dust level sensor makes it safe and convenient to monitor dust collection containers. The sensor uses a signal to detect the level of dust inside the container.





ANTI-RAMP RAILS

Rails guide filter in place and stops them from overlapping each other.



LIFT RAIL DOOR STOP

Stops the door from closing if the rails are not in the proper upright position.



SURE STOP SYSTEM

Ensures the filters are installed properly or the door will not close, using pan indexing channel and door indexing bar.

DELTA MAXXTM

PRIME

MOST ADVANCED CARTRIDGE FILTER



SURE STOP SYSTEM

Ensures filters are installed properly



DOUBLE GASKET

Double layer of protection to ensure a good seal with a single piece design

UNIQUE PAN SHAPE

Prevents filter ramping for safety



COMPLETELY GROUNDED

Filters are grounded to the dust collector

400sq. ft. OF MEDIA

More media than leading filter competitors

OVAL DESIGN

Oval design maximizes surface area



The DeltaMAXX Prime cartridge filter is available exclusively for Imperial Systems dust collection units. This patent pending design offers a new level of safety and performance. Our Nanofiber material already sets the standard for high efficiency filtration and long filter life.

PATENTED 11,857,905

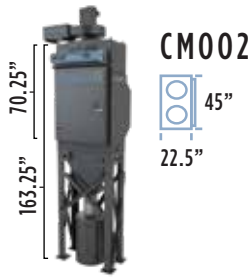

CM002
 Filter Area (sq. ft.) - 800
 Nominal CFM Range - 350-3600
 Weight (lbs.) - 1600

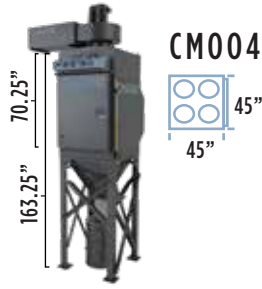

CM004
 Filter Area (sq. ft.) - 1600
 Nominal CFM Range - 700-7200
 Weight (lbs.) - 2000

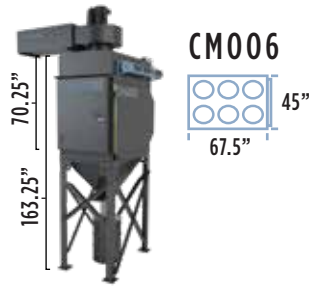

CM006
 Filter Area (sq. ft.) - 2400
 Nominal CFM Range - 1050-10800
 Weight (lbs.) - 2700

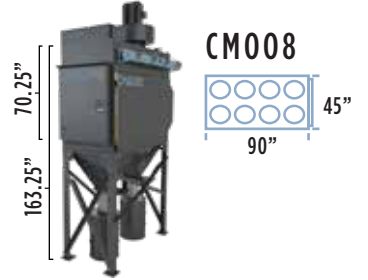

CM008
 Filter Area (sq. ft.) - 3200
 Nominal CFM Range - 1400-14400
 Weight (lbs.) - 3150

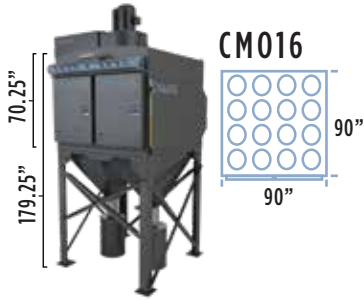

CM016
 Filter Area (sq. ft.) - 6400
 Nominal CFM Range - 2800-28800
 Weight (lbs.) - 5250

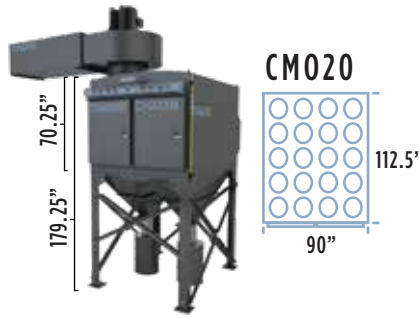

CM020
 Filter Area (sq. ft.) - 8000
 Nominal CFM Range - 3500-36000
 Weight (lbs.) - 6050

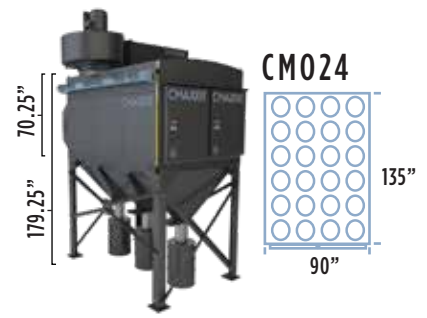

CM024
 Filter Area (sq. ft.) - 9600
 Nominal CFM Range - 4200-43200
 Weight (lbs.) - 7200

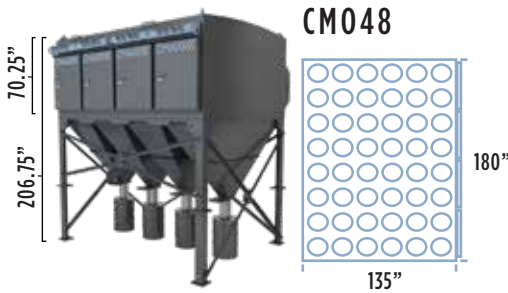

CM048
 Filter Area (sq. ft.) - 19200
 Nominal CFM Range - 8400-86400
 Weight (lbs.) - 13000

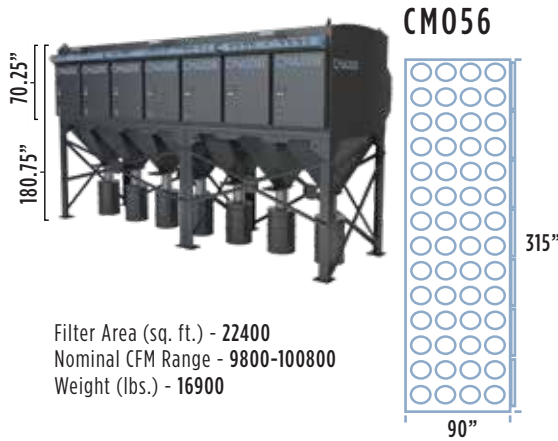

CM056
 Filter Area (sq. ft.) - 22400
 Nominal CFM Range - 9800-100800
 Weight (lbs.) - 16900



CM084
 Filter Area (sq. ft.) - 24000
 Nominal CFM Range - 10500-108000
 Weight (lbs.) - 18100

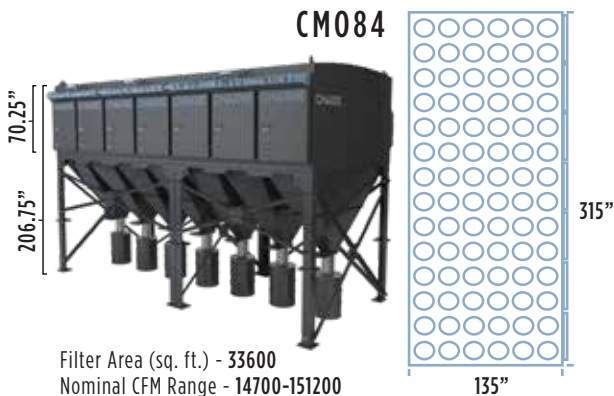

CM084
 Filter Area (sq. ft.) - 33600
 Nominal CFM Range - 14700-151200
 Weight (lbs.) - 25200



CM096
 Filter Area (sq. ft.) - 38400
 Nominal CFM Range - 16800-172800
 Weight (lbs.) - 28800

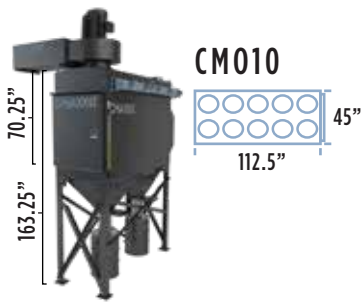

CM010

Filter Area (sq. ft.) - 4000
 Nominal CFM Range - 1750-18000
 Weight (lbs.) - 3600

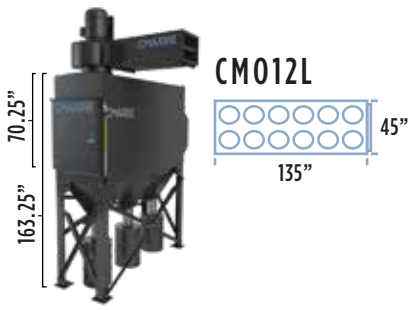

CM012L

Filter Area (sq. ft.) - 4800
 Nominal CFM Range - 2100-21600
 Weight (lbs.) - 4500

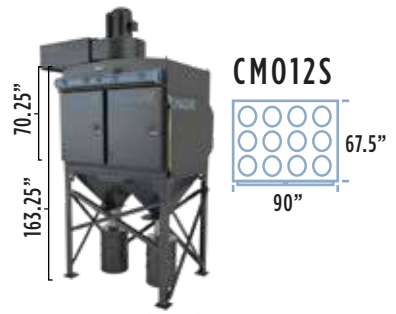

CM012S

Filter Area (sq. ft.) - 4800
 Nominal CFM Range - 2100-21600
 Weight (lbs.) - 4260

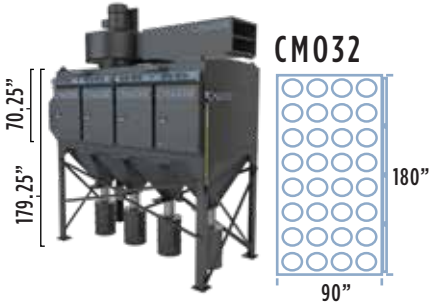

CM032

Filter Area (sq. ft.) - 12800
 Nominal CFM Range - 5600-57600
 Weight (lbs.) - 10000

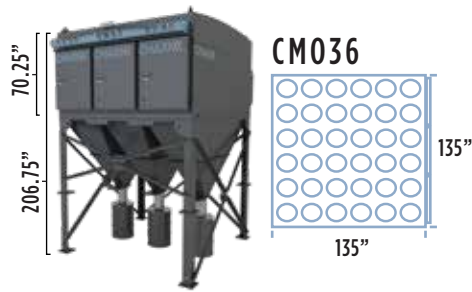

CM036

Filter Area (sq. ft.) - 14400
 Nominal CFM Range - 6300-64800
 Weight (lbs.) - 10900

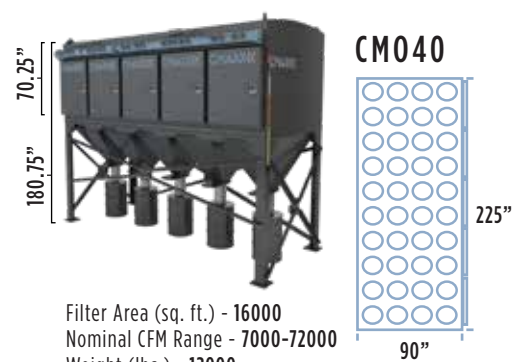

CM040

Filter Area (sq. ft.) - 16000
 Nominal CFM Range - 7000-72000
 Weight (lbs.) - 12000

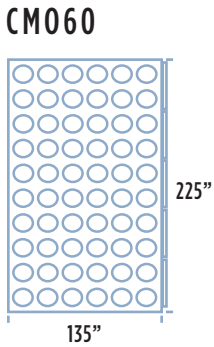

CM060



CM064

Filter Area (sq. ft.) - 25600
 Nominal CFM Range - 11200-115200
 Weight (lbs.) - 19200

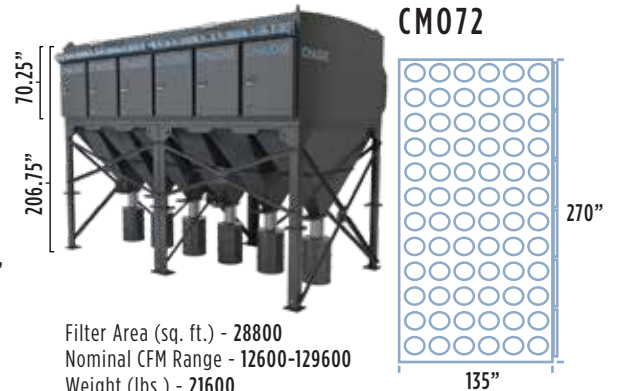

CM072

Filter Area (sq. ft.) - 28800
 Nominal CFM Range - 12600-129600
 Weight (lbs.) - 21600

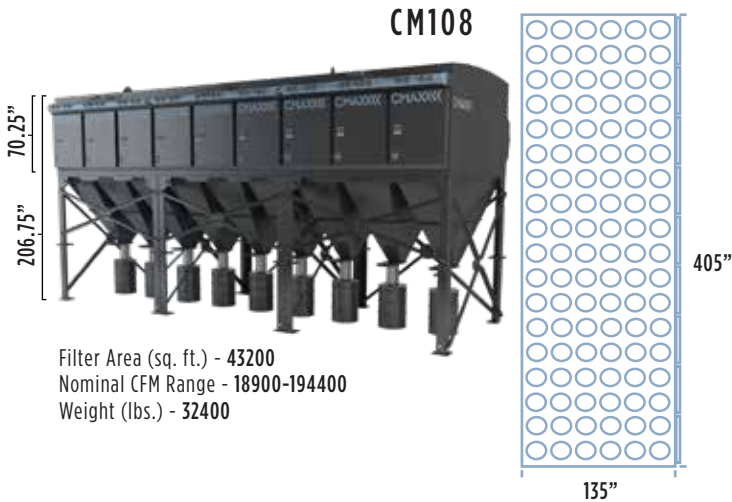

CM108

Filter Area (sq. ft.) - 43200
 Nominal CFM Range - 18900-194400
 Weight (lbs.) - 32400

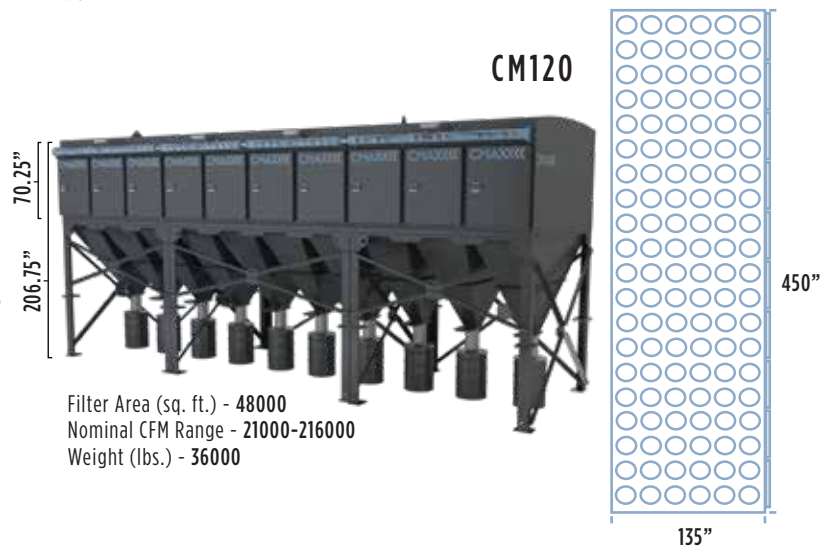

CM120

Filter Area (sq. ft.) - 48000
 Nominal CFM Range - 21000-216000
 Weight (lbs.) - 36000



BREATHE BETTER, WORK SAFER

IMPERIAL SYSTEMS INC.

**7320 West Market St.
Mercer, PA 16137**

800.918.3013

IMPERIALSYSTEMSINC.com

